

STYL'One Nano

THE MOST ADVANCED BENCHTOP TABLET PRESS



« Let your
powder speak
to you »

THE NEW STYL'ONE NANO
is a revolutionary benchtop R&D press for
demanding formulation and scientists with
price performance in mind.

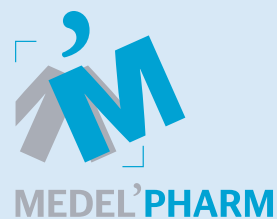

Design for every formulation scientist with price performance in mind

POWDER COMPACTION SCIENCE CONCENTRATED IN A BENCHTOP R&D PRESS

Tableting has never been so easy and so powerful, from pure API characterization to formulation assessment.

Single-punch presses are ideal at formulation stage: easy to operate, easy to clean and for small amounts of API. STYL'One Nano offers all of this and more, including the unique and powerful drive technology, normally reserved for an Elite of premium compaction simulators.

Scientists can use the flexibility to drive the punches at high velocity to replicate the pre- and main compression of a small rotary tablet press in order to prevent tablet defects such as capping.

Premium data analysis software allows you to plot the recommended profiles as set forth in USP <1062>. Start building your own API & excipient database with STYL'One Nano now!

COMPACT & MOBILE, SMALL FOOTPRINT

This compact table top unit can be installed on an existing bench, on its optional mobile base or even inside a downflow booth.

UNCOMPROMISED INSTRUMENTATION

High resolution force and position sensors are fitted on both punches. Pre- and main compression forces, ejection force and elastic recovery are at your disposal.

PRE- AND MAIN COMPRESSION

A powerful drive technology allows to replicate the pre- and main compression of research rotary presses at the same velocity.

FAST BOTTOM PUNCH DYNAMICS

Compression displacement is performed by the bottom punch which is similar to the movements on rotary tablet presses, where most of the pressure is applied from the lower punches. Punch velocity is twice as fast as any eccentric presses.



FORCE AND POSITION CONTROL

Force control is the mode of choice to easily make tablets at a desired force. A must for neat API characterization or to quickly plot tablet breaking force vs compression force. Position control is the preferred choice to mimic rotary tablet presses dynamics and to study the effect of turret speed and/or pre-compression level.

KNOBS FREE

Identical to the flagship STYL'One Evolution, STYL'One Nano is entirely controlled by a software. Each process parameter, such as filling height or compression thickness/force, is precisely entered through a Human Machine Interface (HMI).



The nano the way you want

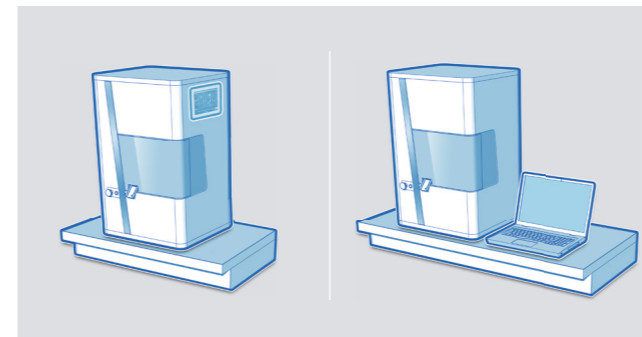

Nano

Nano with Data Analysis Software

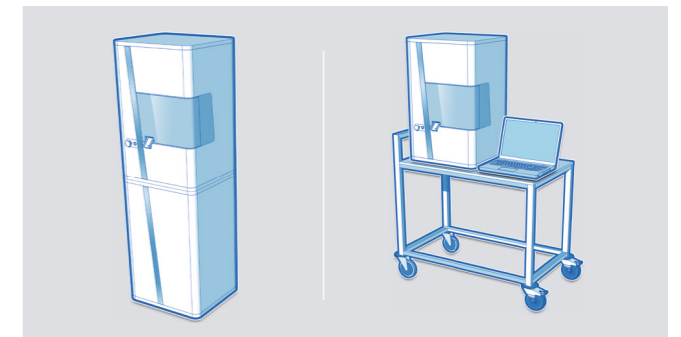

Optional base stands

INDEPENDENT FILL HEIGHT AND COMPRESSION THICKNESS ADJUSTMENT

Unlike eccentric single-punch presses, adjusting the fill height is independent of the compression thickness.

CONNECTION TO HARDNESS TESTERS

Can be connected to virtually any recent hardness tester to ensure data transfer to STYL'One Nano software. Compatible with automatic or semi-automatic 5-parameter testers (tablet breaking force, thickness, length, width, mass).

STANDARD B & D TOOLINGS

Supports standard TSM and Euro B and D tooling of any shapes, including multi-tip.

FULLY INSTRUMENTED WITH STANDARD B&D TOOLING, THIS TABLETING INSTRUMENT IS CONTROLLED BY SOFTWARE IN FORCE OR POSITION MODE.

THE COMPRESSION PROFILE THE WAY YOU WANT

USP <1062> on tablet characterization is natively integrated into STYL'One Nano software. Manufacturability profiles (tablet breaking force vs compression force) or tabletability profiles (tensile strength vs pressure) are readily available. Compressibility and compactibility profiles are also available when powder true density is known.

PROFILES

Saw Tooth, Square, R&D Rotary Press

Deep material characterization is now accessible by these additional profiles described in USP <1062>. Square, also called Extended Dwell-Time, is a must to analyse particle rearrangement. Saw tooth is largely used to analyze and standardize strain rate sensitivity tests (speed sensitivity).

Technical data

Number of press stations	1
Tool type	EU / TSM : B-D D-441
Die	D,B,BB,BBS
Precompression force	50 KN
Compression force	50 KN
Tablet diameter max	25 mm
Filling depth max	23 mm (EU/TSM D)
Upper punch insertion depth	3 mm
Feeder	Programable Oscillating Gravity 300ml capacity
Load applied	From lower punch
Output	1 800 tabs/hour
Compression mode	Force or displacement driven
Compression dynamics (profiles)	Small rotary press Saw-tooth Square (extended dwell time - up to 3s)
Machine dimensions (LxWxH)	628 x 580 x 880 mm (bench top model)
Net weight	Approx. 250 Kg
Power supply / utilities	230 V 1PH+N / 220 V 3PH 50/60Hz, 16 Amps Compressed air 6 bars

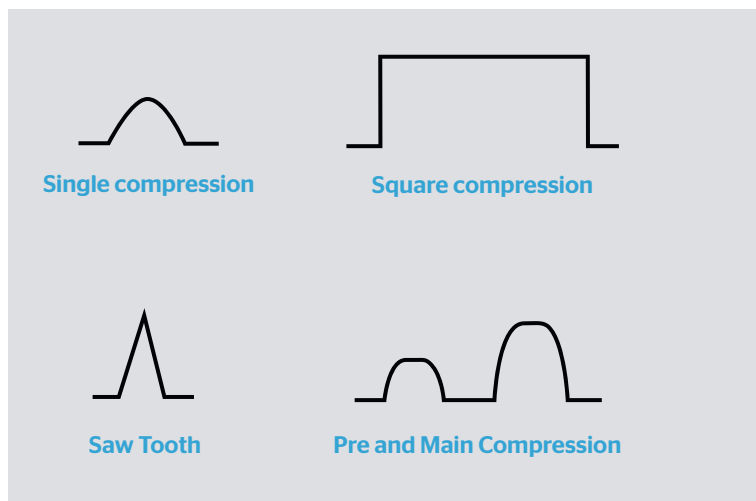

Force/Displacement Control

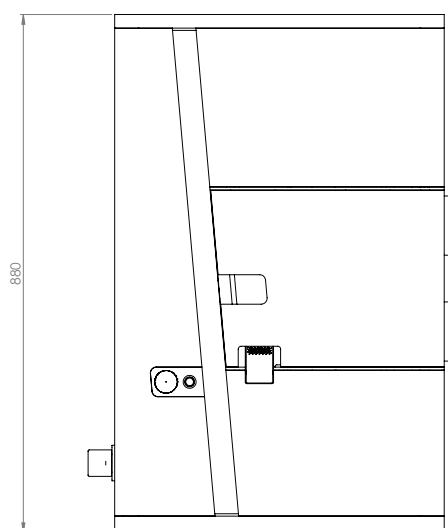

Layout

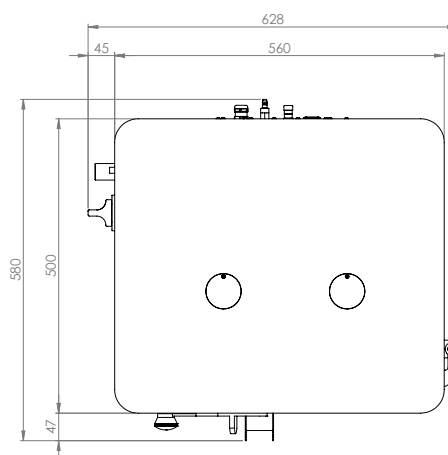

ME-076_EN_B (11 2018)

MEDELPHARM

12, rue des Petites Combes, Z.I.
F-01700 Beynost, France
Phone: +33 478 976 210
E-Mail: contact@medelpharm.com

 STYL'One channel

 
medelpharm.com



MEDELPHARM

THE TABLETING
INSTRUMENT
COMPANY