



Pharmaceuticals

Chemicals

Cosmetics

Food

**PTS – the swiss original
Powder Transfer System**

Powder Handling Excellence

PTS – the swiss original

The highly reliable and safe pneumatic conveying solution

The PTS is a highly effective method for transferring and dispensing both dry and wet powders and granules in a safe and contained manner. Whilst there are many PTSs on the market DEC's system has been unrivalled. Its unique filtration concept with a flat filter membrane makes it the only vacuum dense-phase system currently available that functions at optimum levels for each cycle, differentiating it from the run-of-the-mill systems on the market.

The PTS is a pneumatic conveying system using both vacuum and pressure without relying on gravity to move powders thus eliminating the need for multi floor arrangements. The system is ideal for transferring highly explosive powders and for the transfer of toxic and hygroscopic materials. The PTS eliminates oxygen from the powder and forms a physical barrier to the receiving process equipment. One of the major advantages of this technology is that it separates the air from the powder keeping the receiving vessel inert during the charging operation. It is, therefore, possible to safely charge powder into a reactor, which contains solvents or that is pressurized, without risking explosions.

There are currently over 3000 Powder Transfer Systems operational worldwide.



PTS Cleaning Device (CIP/SIP)

The PTS Cleaning Device ensures Cleaning in Place (CIP/SIP) is easily achieved. The system is fitted with a liquid separator component installed in the upper part of the PTS body. The liquid separator sucks liquids into the system and a float in the main cover prevents the liquid from entering the vacuum line. The PTS body and the powder transfer hose are cleaned at the same time, a considerable advantage over using a spray nozzle.



PTS mobile

DEC also offer the Mobile PTS with all the features of the static system with the additional benefit of being portable. The system can easily be dismantled and relocated anywhere in the production unit. The control panel and vacuum pump remain permanently mounted on the trolley while the PTS can easily be installed on the process equipment to be charged.



The PTS system

The PTS can be easily installed in to your current environment and will significantly enhance any process. A substantial reduction in batch times and accelerated production can be achieved. The system is GMP and ATEX compliant.

Technical Data

PTS	50	80	100	150	200	250	300	400
min/max conveying capacity (l/h) depending on the powder characteristics and the transfer distance								
	10-200	15-500	20-800	50-2000	80-3500	120-6000	160-9000	400-16000
d	50	80	100	150	200	250	300	400
h1	400	450	500	600	600	600	600	850
h2	520	600	680	800	810	830	860	1150

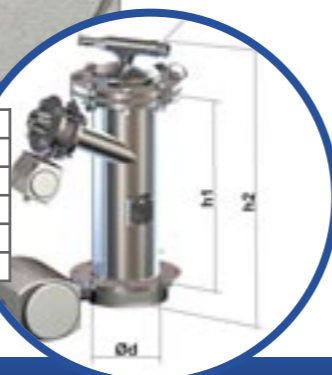

Application Examples

Full processing flexibility – tailored to your needs.
At the core of Dec's Powder Handling Excellence, the PTS encompasses a broad range of applications.



Standard and high containment filling & discharging

In combination with a DCS Drum Containment System the PTS provides a safe solution for filling or emptying big bags and drums (OEB 5)



Small quantity dosing

Accurate and repetitive volumetric dosing of small quantities of powder ranging from 1 mg to 100 g



Single and multiple reactor charging

Safe reliable vessel charging, the oxygen is removed from the powder before entering into the process.



Blending

PTS Batchmixer for fully contained homogeneous powder blending



Filling and packaging facilities

Continuous Liner System for optimized GMP compliant packaging solutions enabling high containment levels. (< 1µg/m3). In combination with the PTS and the Dosivalve this system allows for any equipment discharging and precise dosing into drums/containers.



Switzerland

Dec Group

Z. I. Larges Pièces A
Chemin du Dévent
P. O. Box 9
1024 Ecublens

Tel: +41 21 694 20 40
Fax: +41 21 694 20 59

Germany

Dec Deutschland GmbH

Max-Knöferl-Str. 6
85290 Geisenfeld

Tel: +49 8452 73223 0
Fax: +49 8452 73223 11

Ireland

Dec Ireland

Derry, Barefield
Ennis. Co. Clare
Ireland

Tel: +353 86 606 7001
Fax: +353 65 671 0111

UK

Dec UK Ltd.

The Beetham Suite
Clawthorpe Hall Business Centre
Burton
Lancashire
LA6 1NU

Tel: +44 1524 784 345
Fax: +44 1524 784 353

India

Dietrich Engineering Consultants

India Pvt. Ltd
Churchgate House
Veer Nariman Road 32-34
Mumbai - 400 001

Tel: +91 22 2288 1006
Fax: +91 22 2204 9408

Poland

Tekpro Sp. z o.o.
ul. Wojska Polskiego 9
39-300 Mielec

Tel: +48 17 788 6428
Fax: +48 17 774 5150

USA

Dec USA Inc.

1118 Industrial Pkwy.
Brick, NJ 08724

Tel: +1 732 2027536
Fax: +1 908 6030145

China

Dec China

Building 3, 526 Fute No.3 Road E,
Pilot Free Trade Zone
Shanghai, PRC 200131

Tel: +86 021 2076 5535



Powder Handling Excellence