



TRAY HANDLER™
A flexible platform to fit diverse market needs



THE MIKRON TRAY HANDLER™ – HIGH-PERFORMANCE AND MODULAR PLATFORM FOR MIKRON'S SOLUTIONS

Mikron supplies a highly standard tray handler capable of dealing with a range of applications from single tray to multiple stacks, for tray sizes from 300x400 to 400x600 mm. It's designed for parts that are susceptible to damage or contami-

nation if fed using other methods such as bowl feeders. The standard building blocks concept allows easy integration of additional in-tray process such as lid handling, inkjet printing, quality inspection.

YOUR BENEFITS

Flexible tray handling

- Tray size from 300x400mm to 400x600mm
- Tray quality from single tray handling to multi stack of tray
- Loading / unloading of trays
- Trolley feeding
- Tray rotation for compact stacking of empty trays
- Fully standalone

Additional in-tray processes

- Lid handling
- Inkjet printing
- Quality inspection

Short delivery time

- Fully standard
- Available from stock

Part handling

- Rotation
- Pitch adjustment

Adaptation to environmental constraints

- Pharma for clean room ISO 7 (class 10'000)
- Electronic signature CFR 21 part 11



Mikron Tray Handler

TECHNICAL SPECIFICATIONS

Flexible tray handling system

		STANDARD PLATFORMS	
		SINGLE STACK	MULTI STACK
Integration	Linked to assembly machine via transfer conveyor or direct loading to pallets on main conveyor	✓	✓
Tray sizes	300x400mm and 400x600mm	✓	✓
Speed	One up 40 cycles/min	✓	✓
Dimensions	Width x Depth x Height (mm)	1700 x 2424 x 2300	2500 x 2424 x 2300
Loading	Ergonomic load height (mm)	1100	800-1100
Autonomy	Number of stacks in/out	1/1	3/3
Tray exchange time	2.5 sec	✓	✓
Control System	Industrial PC, real time software	✓	✓
Handling system	Embedded 4-axis Cartesian Robot	✓	✓
Accuracy	Millimeters	+/- 0.05	+/- 0.05
Cleanroom	Compatible for cleanroom ISO 7 (class 10,000)	✓	✓
Validation	Validated base machine according to GAMP 5	✓	✓

THE MIKRON TRAY HANDLER WAS DESIGNED WITH A MODULAR CONCEPT TO MEET THE VARIOUS DEMANDS REQUIRED INTODAYS AUTOMATION MARKET

MODULAR INTEGRATION

The modular concept allows flexibility by adding different types of entrance or exit modules when specific processes are required

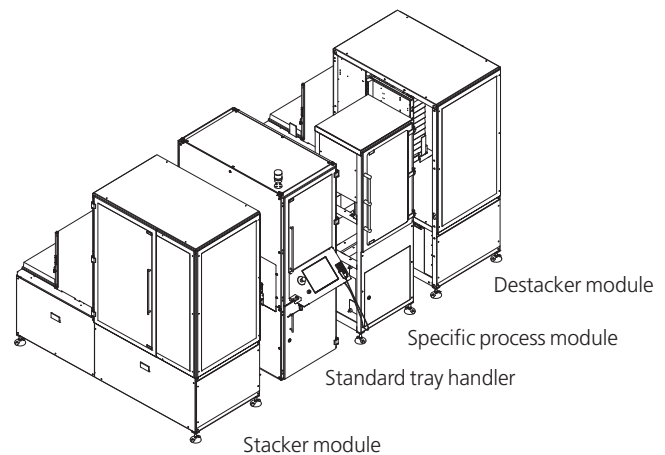

POSSIBLE CONFIGURATIONS

Mikron supplies a highly standard tray handler capable of dealing with a range of applications from single tray to multi stack and designed for parts that are susceptible to damage or contamination if fed using other methods such as bowl feeders.

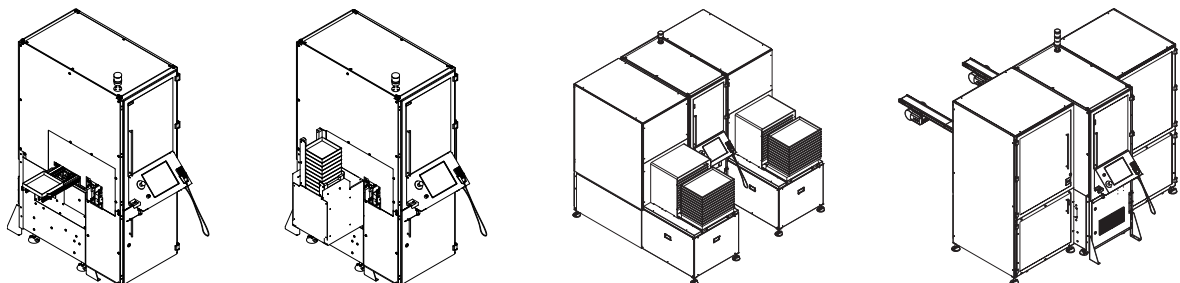

5 REASONS TO WORK WITH MIKRON

1. Proven know-how – over 100 years of experience with precision machinery – close to 40 years in assembly
2. Reliable and technical production solutions with high added value – mastery of complex processes, standard and proven automation platforms
3. Short delivery time – quicker time to market
4. Mikron worldwide organization is committed to your project success – from project fulfillment to 24/7 customer service
5. Long-term partnership – industry references

ABOUT US

Mikron Automation is headquartered in Boudry (Neuchâtel), in a region that is regarded as the heart of the Swiss watchmaking industry. To date, Mikron Automation has installed more than 3,000 assembly and testing systems worldwide. Its international customers operate in the following markets: Pharma and Medical Devices, Automotive Supply, Electrical/Electronics, Consumer Goods and Construction/Building.

Mikron Automation employs around 590 people at its sites in Boudry (Switzerland, headquarters), Berlin (Germany), Denver (USA), Singapore and Shanghai (China).

Mikron SA Boudry
Route du Vignoble 17
2017 Boudry
Switzerland

Tel. +41 32 843 11 11
mbo@mikron.com

Mikron Corp. Denver
8100 S Potomac St.
Englewood CO 80112
USA

Tel. +1 303 364 5222
mde@mikron.com

Mikron Berlin GmbH
Landsbergerstrasse 252
12623 Berlin
Deutschland

Tel. +49 30 9830 7211
mab@mikron.com

Mikron Singapore Pte Ltd
No 3 Loyang Way 1
Singapore 508705

Tel. +65 6299 1589
msi@mikron.com

Mikron Industrial
Equipment (Shanghai) Co., Ltd.
No 358, 3rd Factory
Dong Ye, Dong Jing Town,
Song Jiang District
Shanghai China 201619
Tel. +86 21 6767 9681
msh@mikron.com

www.mikron.com/automation